

## Refrigeration – Reach-in Cabinet

### Reach-in Freezer Cabinet

#### XSF-62D-800



Due to continuous technical development, the image shown may not represent the latest design of the unit.

#### DESCRIPTION

Cabinet freezer with 2 half doors.

Made entirely of AISI 304 internally and AISI 430 externally. Friendly user interface with digital thermostat control for ease of monitoring. Non-CFC and HCFC refrigerant. Polyurethane insulation with density of 40kg/m<sup>3</sup>. Powered with refrigerant type of R404a.

#### OTHER AVAILABLE MODELS

- XSC-62D-800
- XSC-124D-800
- XSC-186D-800
- XSF-124D-800
- XSF-186D-800

#### MAIN FEATURES

- Reach-in Freezer Cabinet with 800 mm depth and 2 half solid doors. Operating temperature from -18°C ~ -20°C.
- Internal volume of 430 liters with size of 520 x 690 x 1210 mm.
- Digital thermostat.
- Designed to perform under tropical ambient condition of 38°C.
- Removable racking system.
- Self-closing doors with removable gasket.
- Includes protection component against voltage drops.
- Fan-assisted cooling system.

#### CONSTRUCTION

- External construction is made entirely with AISI 430.
- Internal construction is made with AISI 304 with 2B surface finish.
- Door thickness of 42 mm.
- Side panel with AISI 430 with 0.8mm thickness. Hairline surface finishing.
- 100mm castor for easy movement.
- Condensing unit is covered with front panel of 0.8 mm thick, 300 mm high and 50 mm panel.

#### PT. KARYA TEKNIK GLOBAL

[www.neotechindonesia.com](http://www.neotechindonesia.com)

PT. Karya Teknik Global reserves the right to make product alterations and or price adjustments at any time and can not be held responsible for any printing errors or omissions.

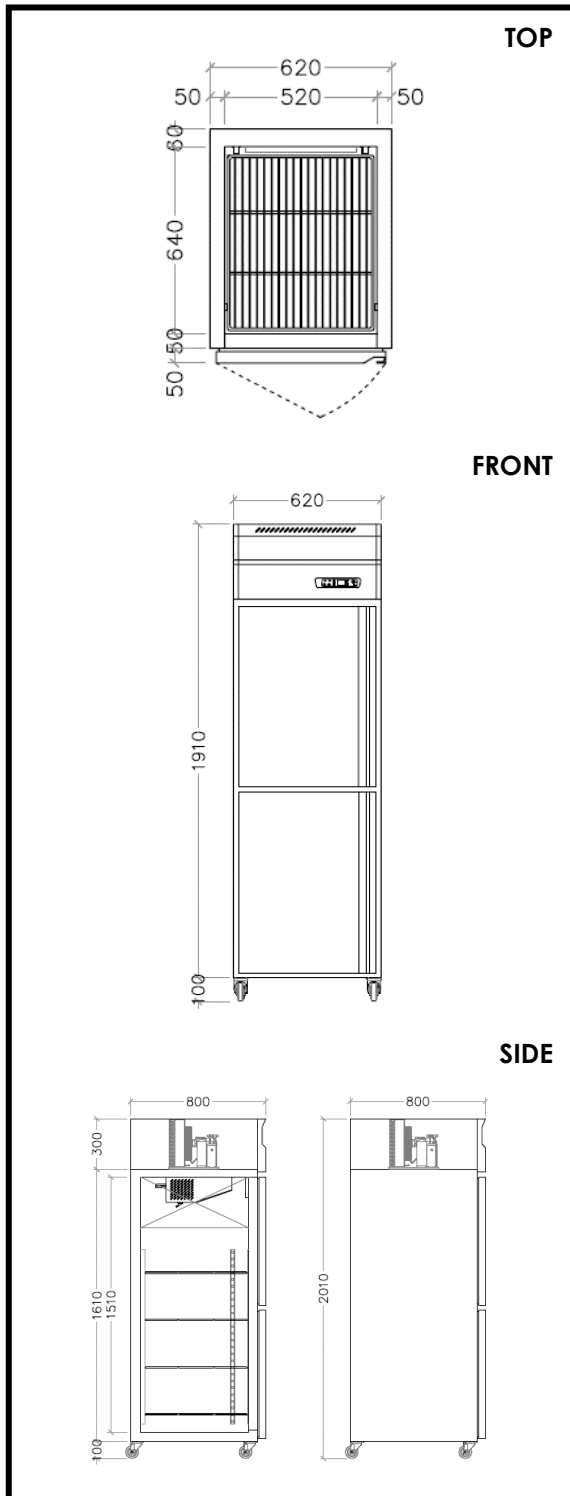

\*Overall Dimension in mm

## TECHNICAL DATA

### External Dimension

Width	: 620 mm
Depth	: 800 mm
Height	: 2010 mm

### Internal Dimensions

Width	: 520 mm
Depth	: 690 mm
Height	: 1210 mm
Volume	: 430 liters

### Refrigeration Properties

Refrigerant	: R404a
Temperature	: -18°C ~ -20°C
Control Type	: Digital Thermostat

### Electrical Supply Data

Connected Load	: 853W
Voltage	: 220V / 1Ph / 50Hz

### PACKAGING DATA

Width	: 630 mm
Depth	: 810 mm
Height	: 2010 mm
Volume	: 1.02 m <sup>3</sup>

### INCLUDED ACCESSORIES

- Nylon-coated wire racks 500 x 600 mm
- Power cable, 2 meter (3x2.5 mm)

### OPTIONAL ACCESSORIES

- Stainless Steel wire racks 500 x 600 mm
- Extra Nylon-coated wire rack

## PT. KARYA TEKNIK GLOBAL

[www.neotechindonesia.com](http://www.neotechindonesia.com)

PT. Karya Teknik Global reserves the right to make product alterations and or price adjustments at any time and can not be held responsible for any printing errors or omissions.